

Top Opening

Side Opening

Side Opening
with 5in hole

Side Opening
with slot opening

Tools Required

- Safety glasses
- **CAUTION!** This litter receptacle is heavy. To avoid injury or damage to the finish, we recommend using a two-wheeled hand truck to move this item.
- Litter receptacle ships fully assembled with freestanding glides.
- Anchoring hardware for surface mount option. Two anchors, 3/8" diameter or less, are required per unit. The base casting adds 1-1/2" to the anchor length. The installer is responsible for anchoring hardware suitable for site conditions. Corrosion resistant anchors are recommended.



PROCEDURE FOR INSTALLATION:

FOR SURFACE MOUNTED LITTER RECEPTACLE:

Note: Unit can be surface mounted with freestanding glides installed.

1. Place the unit in the desired position. Open the door to check clearance.
2. Remove the liner and mark anchor locations through the holes in the base.
3. Move the unit to allow access for drilling holes.
4. Drill holes at marked locations according to anchor manufacturer's specification.
5. Complete the anchor installation according to the anchor manufacturer's instructions.

FOR LOCK OPTION:

- Litter receptacle locks are keyed alike. Each receptacle is shipped with two keys. The key can be removed in both the locked and unlocked position.

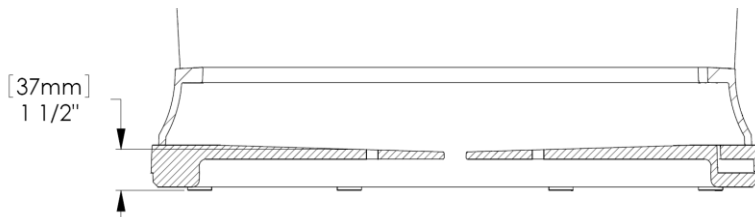

Base casting section view

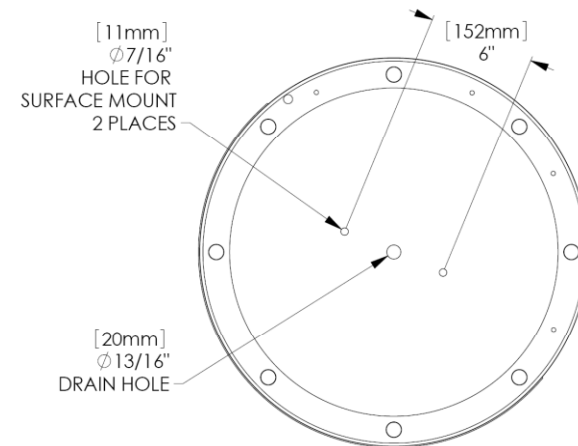

Base casting bottom view

ASSEMBLE WITH CARE! Pangard II® Polyester Powdercoat is a strong, long-lasting finish. To protect this finish during assembly, place unwrapped powdercoated parts on packaging foam or other non-marring surface. Do not place or slide powdercoated parts on concrete or other hard or textured surface – this will damage the finish causing rust to occur. Use touch-up paint on any gouges in the finish caused by assembly tools.