

Top Opening

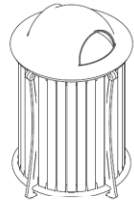

Side Opening

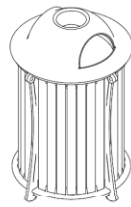

Side Opening with sand pan

Included components:

- Litter ships fully assembled.

Tools Required for Surface Mounting into concrete:

- Safety glasses
- (4) Stainless steel 3/8-16 drop-in anchors with (4) 3/8-16 x 1" hex socket head cap screws, plus setting tool for drop-in anchors.
- Masonry drill bit, Ø1/2"
- 5/16" hex key
- Blanket or other padded material, for protecting powdercoat finish

PROCEDURE FOR INSTALLATION:

1. Prepare proper concrete slab as required.
2. Freestanding litter ships with glides installed. Litter can be set in place.

Note: DO NOT DRAG unit across concrete or other rough surfaces. This could damage the powdercoat finish.

For SURFACE MOUNT litter:

1. Set litter in place and mark hole locations.
2. Move litter and finish marking the holes, see Fig. 2. Drill holes according to Fig. 2. Clear holes of debris. Install drop-in anchors. Drop-in should sit flush with grade. Set anchor with setting tool. If top of drop-in anchor sits below grade, a longer screw may be required.
3. Set litter over holes and install anchors. Leave glides installed.

ASSEMBLE WITH CARE! Pangard II® Polyester Powdercoat is a strong, long-lasting finish. To protect this finish during assembly, place unwrapped powdercoated parts on packaging foam or other non-marring surface. Do not place or slide powdercoated parts on concrete or other hard or textured surface – this will damage the finish causing rust to occur. Use touch-up paint on any gouges in the finish caused by assembly tools.

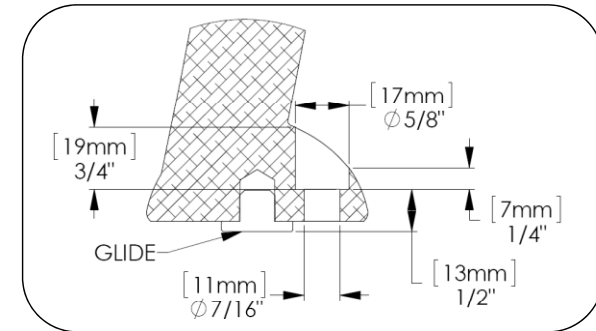

Fig. 1 – Litter leg detail

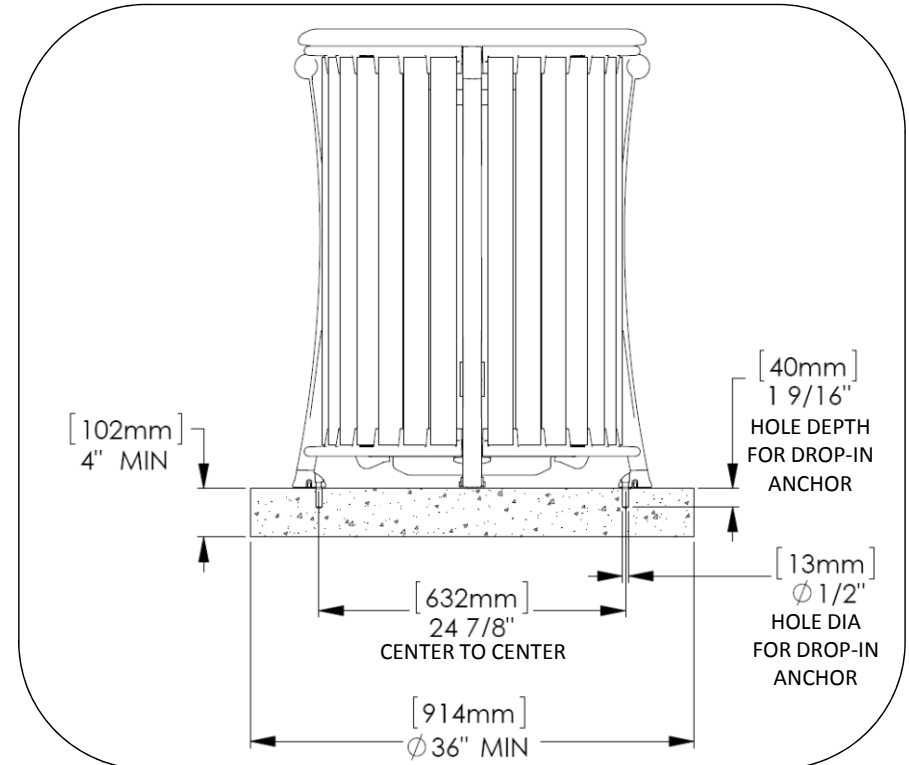

Fig. 2 – Anchor hole details for drop-in anchors