

Included components: No assembly required. Backrest ships preinstalled.

For surface mounting(removable):

- M5 side set screws (may be installed in unit)
- M6 set screw for use in bushing
- M6 bushing

For embedded:

- M8 x 60mm set screw

For LED light kit:

- LED strips pre-installed
- Driver(s)

Tools required:

- sand for ballast if specified (ballast may not be used with LED kit)

For surface mounting(removable):

- 2.5mm hex key for side set screw
- 3mm hex key for set screw in bushing
- Ø20mm masonry drill bit
- Epoxy

For embedding:

- 4mm hex key
- Ø10mm masonry drill bit
- Epoxy

For LED kit:

- Wiring connectors

INSTALLATION STEPS: Freestanding unit may be set in place.

Surface mount installation:

1. Thread M6 set screw into bushing.
2. Position M6 set screw/bushing assembly in threaded insert on bottom of unit. Tighten side set screw to secure. See Fig. 2 and 2A.
3. Set unit in position. Mark hole locations.
4. Move unit and drill Ø20mm holes to 60mm depth. Clear holes of debris.
5. Fill holes partially with epoxy.
6. With set screw/bushing assemblies still secured to unit, set unit back in position, installing bushings into epoxy-filled holes. Allow epoxy to cure.
7. Loosen side set screws to remove product.

Embedded installation: (cannot be used with LED kit)

1. Thread M8 set screws into threaded inserts in bottom of unit. See Fig. 3.
2. Set unit in position. Mark hole locations.
3. Move unit and drill Ø10mm holes to 60mm depth. Clear holes of debris.
4. Fill holes partially with epoxy.
5. With set screws threaded into the unit, set unit back in position, installing set screws into epoxy-filled holes. Allow epoxy to cure.
6. Unit is permanently fixed and cannot be removed without damage.

Adding sand for ballast: (sand ballast cannot be used with LED kit)

1. Flip unit upside down and unscrew inspection hatch cover.
2. Add appropriate amount of sand for weight.
3. Reinstall hatch cover. Flip unit over and place in position.

LED kit:

1. Open inspection hatch.
2. Verify secure connections from LED strips to driver.
3. Connect driver to line-in voltage through cable gland.
4. Replace inspection hatch cover and set in position.

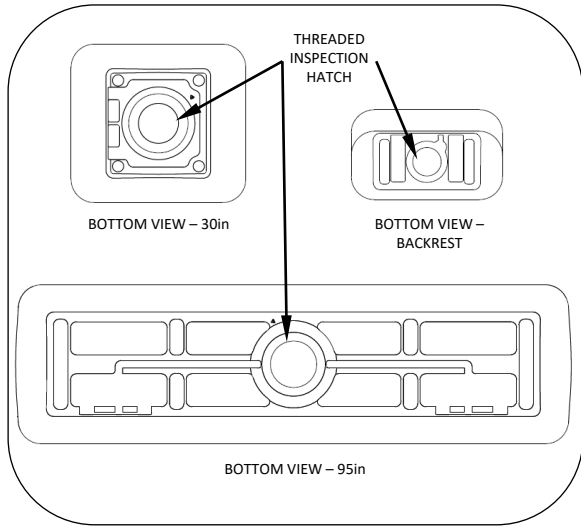

Fig. 1 - anchor components

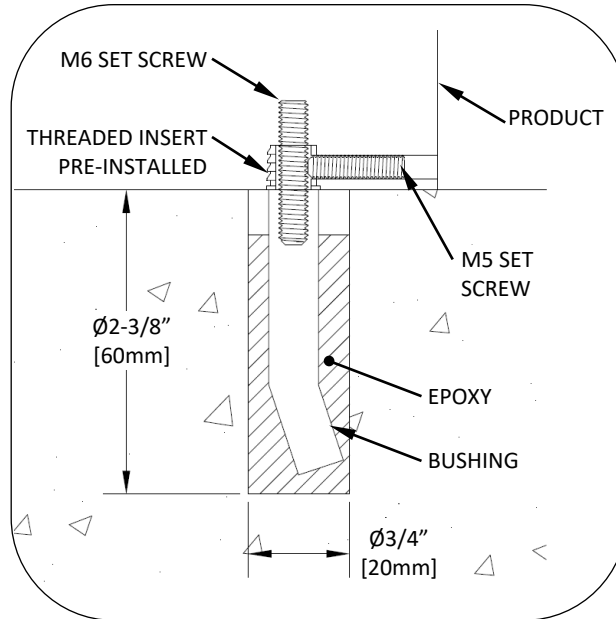

Fig. 2 - surface mount anchor detail

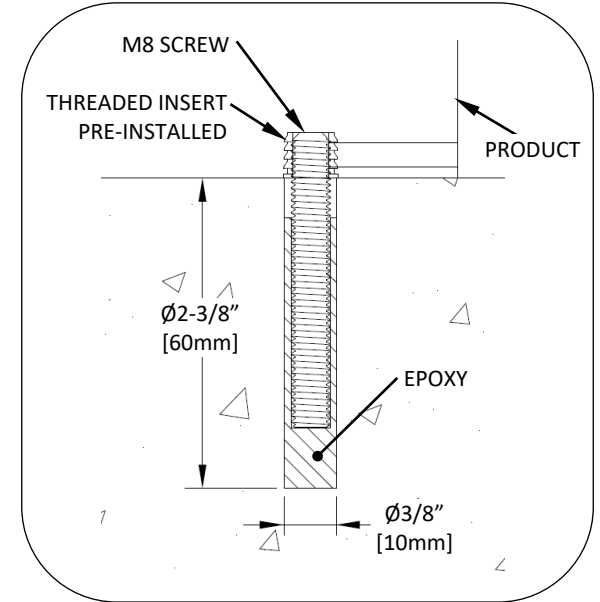

Fig. 3 - embedded anchor detail

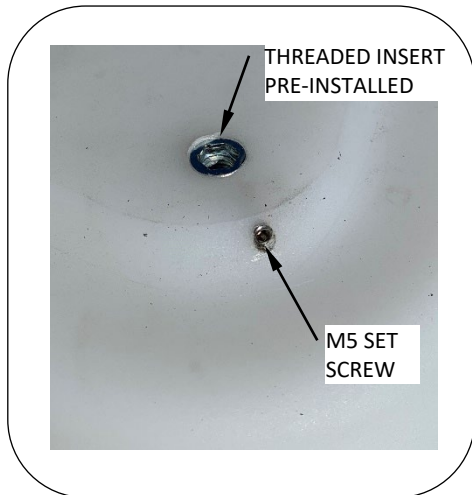

Fig. 1A - bottom view of insert and side screw



Fig. 2A - bushing detail

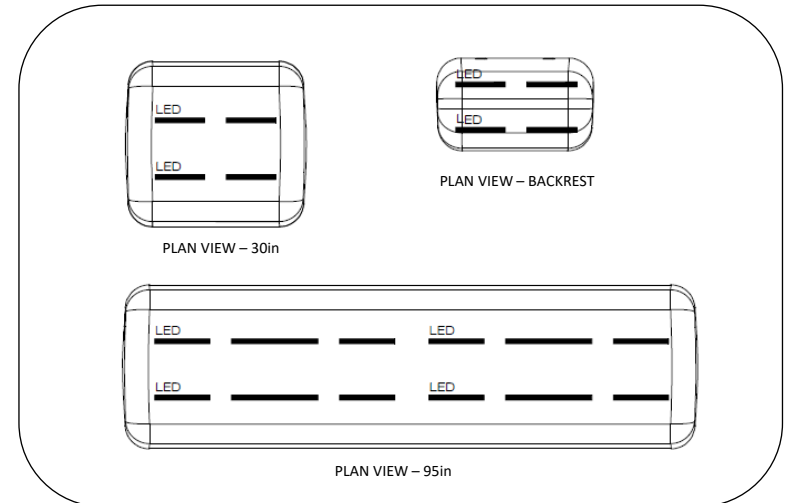

Fig. 4 - LED strip locations, pre-installed (plan view)