



landscapeforms®

**Air Collection**

## Inspiration is in the air.

The Air Collection begins a new chapter in Landscape Forms' long-standing collaborative relationship with Barcelona-based design firm, Escofet. It is inspired by the concept of "lightness," both as a physical characteristic and as an aesthetic captured in the joyous, playful and casual presence the Air Collection brings to outdoor settings.

Constructed of rotomolded high-density polyethylene with hollow interiors, the Air Collection's five seating elements translate Escofet's bold, iconic aesthetic to a material that's light, durable and versatile – perfectly suited for adaptable outdoor spaces, indoor spaces, transition spaces, and on rooftops, decks and balconies.







## Extasi Air

Using its unique triangular shape and softly rounded edges, Extasi Air fulfills the need for a lightweight, low and backless bench that communicates intimacy and comfort in interesting and colorful ways.

*Designer: Arriola & Fiol, arquitectes*

## Twig Air

Twig Air is a branching bench system that embodies the concepts of modularity, fluidity, connection and interactivity with its users. It maintains the same geometry and cross-section across its three arms to encourage organic, conversational and free-flowing arrangements.

*Designer: Alexander Lotersztain*





## Starfish Air

Starfish Air's biomorphic, asymmetric radial design allows for flexible grouped or individual use. Joined at adjacent ends or scattered throughout an area, Starfish Air creates a constellation of seating that welcomes groups, pairs and individuals with subtle differences in bench segment length.

*Designer: Emilio Tuñón*

## Fortunato Air

With rounded lines and visual softness, Fortunato Air juxtaposes its material with forms people expect from plush and yielding furnishings. The combinable rounded cube, rectangle and back modules make for inviting, ergonomic yet hardwearing seating arrangements for outdoor settings.

*Designer: Diego Fortunato*





## Stul Air

A lightweight stool, side table, or complement to other Air Collection elements, Stul Air brings a vibrant and youthful energy to the spaces it inhabits. Ideal for public green areas, terraces, playgrounds, even indoor spaces, Stul Air is a versatile detail in a variety of contexts.

*Designer: Escofet\_lab*



## **A breath of fresh air for the landscape.**

The Air Collection's personality is one of celebration, leisure, freedom, spontaneity, and the sustainable revival of social outdoor spaces. Thanks to its lightness and portability, the collection can be both programmable or fixed in place. Unanchored, Air enables people to create their own layout in situ, but with optional hidden surface mounts or sand ballast, the seating elements can take on a more permanent presence. Additionally, HDPE opens up a world of color like few other materials can, ranging from vibrant showpieces to calming, earth toned complements. All white pieces offer the added option of internal lighting to create a dramatic glow at night. Despite their rigidity, Air Collection seating elements have a distinct softness—a micro-textured surface provides a pleasant tactile experience, while generously rounded edges and corners give the appearance of pliability.







## Designed to tread lightly.

As mono-material HDPE site furnishings, Air plays an important role in furthering a circular economy, utilizing one of the single most commonly recycled materials in the US. This enables black pieces from the Air collection to be constructed from 100% recycled material and all pieces to be easily and entirely recycled at the end of their lives. But being completely non-porous and fade-resistant, Air's HDPE surfaces are designed for all-weather longevity with minimal maintenance.

## Materials

### Escofet High Density Polyethylene (HDPE)



Black



White



Steel Blue



Brilliant Blue



Orange



Lime Green



Colza Yellow



**Statement of Line**

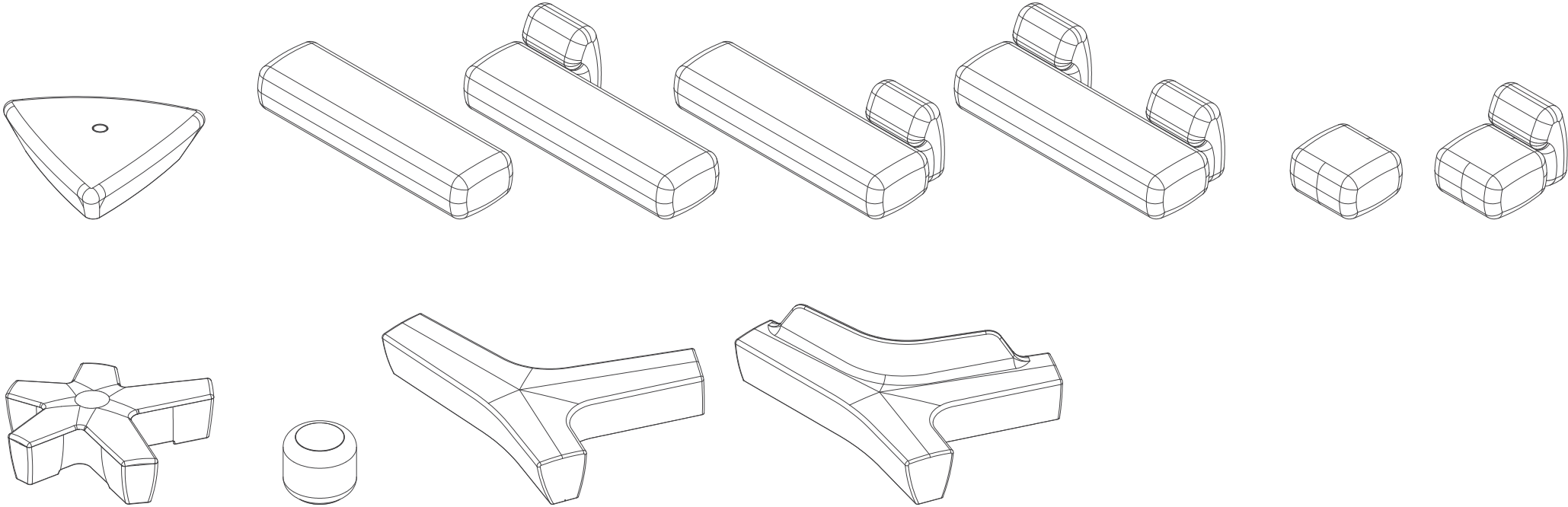



landscapeforms®

**Air Collection**